



<b>Model Name</b>	PPD-332T8M
<b>Ballast Type</b>	Electronic
<b>Starting Method</b>	Program Start
<b>Lamp connection</b>	Parallel
<b>Input Voltage</b>	347V
<b>Input Frequency</b>	60Hz
<b>Warranty</b>	5 Years $TC \leq 75^{\circ}C$ 3 Years $75^{\circ}C \leq TC \leq 90^{\circ}C$

## Safety & Performance



- One or Two Lamps
- UL/cUL Listed
- UL Type 1 Outdoor
- FCC part 18 Class A
- Sound Rated Class A
- Class P Thermally Protected
- High Power Factor
- Surge Protected
- Auto Restart
- No PCBs
- Open Circuit Voltage 600V
- Type HL

## Wire Diagram

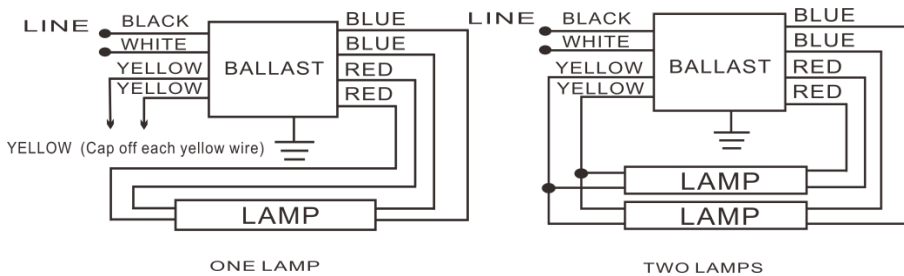

Lead Length	Inch	Cm
Black	18.8	48
White	18.8	48
Blue	30.9	78.5
Red	30.9	78.5
Yellow	46.4	118

Maximum Wiring Distance (at full load) is 18AWG/18Feet  
Case must be grounded

## Enclosure

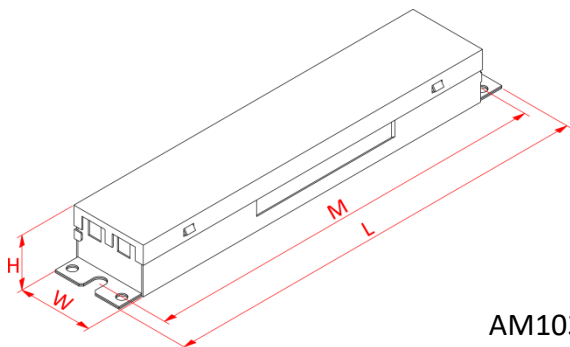

AM103

Enclosure	Inch	Cm
Length(L)	9.5	24.1
Width(W)	1.7	4.3
Height(H)	1.2	3.05
Mounting(M)	8.9	22.6



## Electrical Specification with Different Lamps

Lamp Type	No. of Lamps	Input Voltage (V)	Rated Lamp Watts	Start Temp Min. (F/C)	Input Current (Amps)	Input Power (ANSI Watts)	Ballast Factor	THD Max. (%)	Power Factor	Lamp Current Crest Factor Max.	BEF
F32T8	2	347	32	0/-18	0.16	55	0.87	10	0.99	1.7	1.58
	1				0.10	33	1.08	10	0.98		3.27
F25T8	2	347	25	0/-18	0.13	44	0.95	10	0.99	1.7	2.16
	1				0.08	28	1.13	15	0.98		4.04
F17T8	2	347	17	0/-18	0.10	33	1.03	15	0.98	1.7	3.12
	1				0.05	18	1.45	20	0.97		8.06
F40T8	1	347	40	32/0	0.12	35	0.85	15	0.98	1.7	2.43
F32T8/ES (30W)	2	347	30	32/0	0.15	53	0.87	10	0.99	1.7	1.64
	1				0.10	33	1.08	15	0.98		3.27
F32T8/ES (28W)	2	347	28	32/0	0.14	48	0.87	10	0.99	1.7	1.81
	1				0.09	31	1.08	15	0.98		3.48
F32T8/ES (25W)	2	347	25	32/0	0.13	44	0.87	15	0.99	1.7	1.98
	1				0.08	27	1.08	15	0.98		4.00