



<b>Model Name</b>	EPT-332T8M
<b>Ballast Type</b>	Electronic
<b>Starting Method</b>	Instant Start
<b>Lamp connection</b>	Parallel
<b>Input Voltage</b>	347V
<b>Input Frequency</b>	60Hz
<b>Warranty</b>	5 Years $TC \leq 75^{\circ}C$ 3 Years $75^{\circ}C \leq TC \leq 90^{\circ}C$

## Safety & Performance



- Three or Four Lamps
- UL/cUL Listed
- UL Type 1 Outdoor
- FCC part 18 Class A
- Sound Rated Class A
- Class P Thermally Protected
- High Power Factor
- Surge Protected
- Auto Restart
- No PCBs
- Type HL
- NRCAN Energy Verified

## Wire Diagram

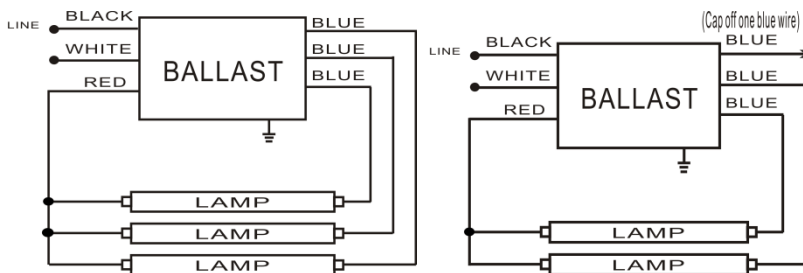

Lead Length	Inch	Cm
Black	18.8	48
White	18.8	48
Blue	30.9	78.5
Red	46.4	118

Maximum Wiring Distance (at full load) is 18AWG/18Feet  
Case must be grounded

## Enclosure

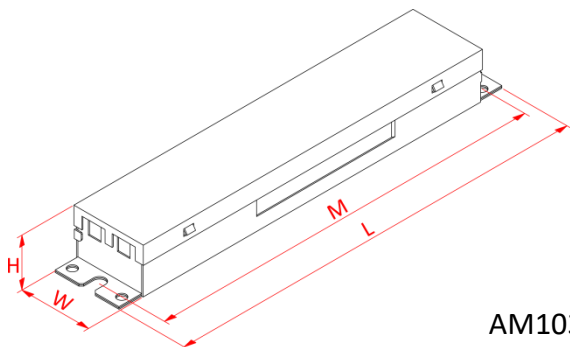

AM103

Enclosure	Inch	Cm
Length(L)	9.5	24.1
Width(W)	1.7	4.3
Height(H)	1.2	3.05
Mounting(M)	8.9	22.6



## Electrical Specification with Different Lamps

Lamp Type	No. of Lamps	Input Voltage (V)	Rated Lamp Watts	Start Temp Min. (F/C)	Input Current (Amps)	Input Power (ANSI Watts)	Ballast Factor	THD Max. (%)	Power Factor	Lamp Current Crest Factor Max.	BEF
F32T8	3	347	32	0/-18	0.24	83	0.88	10	0.99	1.7	1.06
	2				0.19	63	1.02	15	0.98		1.62
F25T8	3	347	25	0/-18	0.18	64	0.88	15	0.98	1.7	1.38
	2				0.14	49	1.01	15	0.98		2.06
F17T8	3	347	17	0/-18	0.13	45	0.90	15	0.98	1.7	2.00
	2				0.10	35	1.04	15	0.98		2.97
F40T8	2	347	40	32/0	0.23	78	0.89	10	0.99	1.7	1.14
F32T8/ES (30W)	3	347	30	32/0	0.22	77	0.89	10	0.99	1.7	1.16
	2				0.18	61	1.02	15	0.98		1.67
F32T8/ES (28W)	3	347	28	32/0	0.21	72	0.89	10	0.99	1.7	1.24
	2				0.16	55	1.02	15	0.98		1.85
F32T8/ES (25W)	3	347	25	32/0	0.19	65	0.89	15	0.98	1.7	1.37
	2				0.14	49	1.02	15	0.98		2.08