



| | |
|------------------------|---|
| Model Name | EST-340M |
| Ballast Type | Electronic |
| Starting Method | Rapid Start |
| Lamp connection | Series |
| Input Voltage | 347V |
| Input Frequency | 60Hz |
| Warranty | 5 Years $TC \leq 75^{\circ}C$ 3 Years $75^{\circ}C \leq TC \leq 90^{\circ}C$ |

Safety & Performance



- Maximum Three lamps
- UL/cUL Listed
- UL Type 1 Outdoor
- FCC part 18 Class A
- Sound Rated Class A
- Class P Thermally Protected
- High Power Factor
- Surge Protected
- Auto Restart
- No PCBs
- Type HL

Wire Diagram

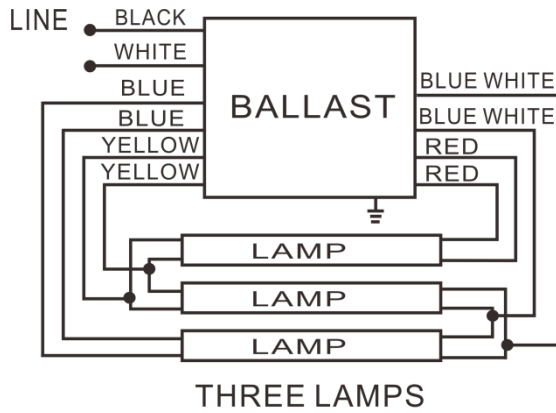

| Lead Length | Inch | Cm |
|-------------|------|------|
| Black | 18.8 | 48 |
| White | 18.8 | 48 |
| Blue | 30.9 | 78.5 |
| Red | 30.9 | 78.5 |
| Yellow | 46.4 | 118 |
| Blue/White | 30.9 | 78.5 |

Maximum Wiring Distance (at full load) is 18AWG/18Feet
Case must be grounded

Enclosure

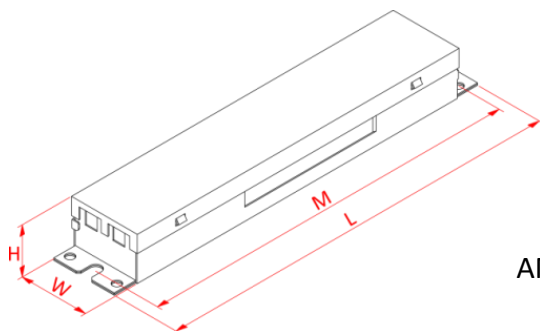

AM103

| Enclosure | Inch | Cm |
|-------------|------|------|
| Length(L) | 9.5 | 24.1 |
| Width(W) | 1.7 | 4.3 |
| Height(H) | 1.2 | 3.05 |
| Mounting(M) | 8.9 | 22.6 |



Electrical Specification with Different Lamps

| Lamp Type | No. of Lamps | Input Voltage (V) | Rated Lamp Watts | Start Temp Min. (F/C) | Input Current (Amps) | Input Power (ANSI Watts) | Ballast Factor | THD Max. (%) | Power Factor | Lamp Current Crest Factor Max. | BEF |
|-----------|--------------|-------------------|------------------|-----------------------|----------------------|--------------------------|----------------|--------------|--------------|--------------------------------|------|
| F40 T12 | 3 | 347 | 40 | 32/0 | 0.2 | 67 | 0.83 | 10 | 0.99 | 1.7 | 1.24 |
| F40 T10 | 3 | 347 | 40 | 32/0 | 0.1 | 35 | 0.88 | 10 | 0.99 | 1.7 | 2.32 |
| F34 T12 | 3 | 347 | 34 | 32/0 | 0.18 | 62 | 0.85 | 10 | 0.99 | 1.7 | 1.37 |
| F30 T12 | 3 | 347 | 34 | 32/0 | 0.1 | 38 | 0.88 | 10 | 0.99 | 1.7 | 2.32 |