



<b>Model Name</b>	EST-320M
<b>Ballast Type</b>	Electronic
<b>Starting Method</b>	Rapid Start
<b>Lamp connection</b>	Series
<b>Input Voltage</b>	347V
<b>Input Frequency</b>	60Hz
<b>Warranty</b>	5 Years $TC \leq 75^{\circ}C$ 3 Years $75^{\circ}C \leq TC \leq 90^{\circ}C$

## Safety & Performance



- Maximum Three lamps
- Sound Rated Class A
- Auto Restart
- UL/cUL Listed
- Class P Thermally Protected
- No PCBs
- UL Type 1 Outdoor
- High Power Factor
- Type HL
- FCC part 18 Class A
- Surge Protected

## Electrical Specification with Different Lamps

Lamp Type	No. of Lamps	Input Voltage (V)	Rated Lamp Watts	Start Temp Min. (F/C)	Input Current (Amps)	Input Power (ANSI Watts)	Ballast Factor	THD Max. (%)	Power Factor	Lamp Current Crest Factor Max.	BEF
F20 T12	3	347	20	32/0	0.16	55	0.80	10	0.99	1.7	1.45

## Wire Diagram

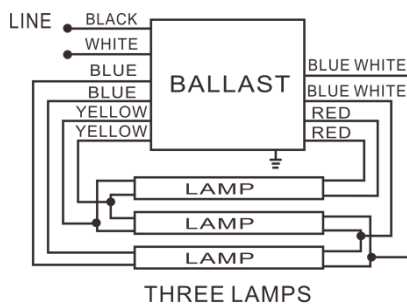

Maximum Wiring Distance (at full load) is 18AWG/18Feet  
Case must be grounded

Lead Length	Inch	Cm
Black	18.8	48
White	18.8	48
Blue	30.9	78.5
Red	30.9	78.5
Yellow	46.4	118
Blue/White	30.9	78.5

## Enclosure

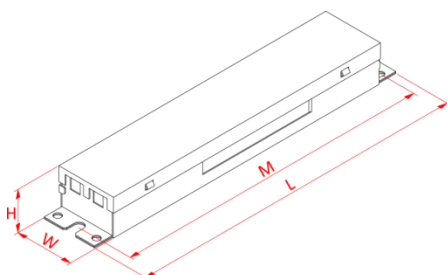

AM103

Enclosure	Inch	Cm
Length(L)	9.5	24.1
Width(W)	1.7	4.3
Height(H)	1.2	3.05
Mounting(M)	8.9	22.6