



<b>Model Name</b>	P3C1250S30DLI 25W
<b>Output Mode</b>	Constant Current
<b>Input Voltage</b>	347 Vac
<b>Input Frequency</b>	50/60 Hz
<b>Isolated Dimming</b>	3 in 1 ( PWM, 1-10V, Resistance) Dim to 1%, 10%, OFF
<b>Surge Rating</b>	2KV
<b>Warranty</b>	5 Years $TC \leq 75^{\circ}C$ 3 Years $75^{\circ}C \leq TC \leq 90^{\circ}C$

## Product Specification



Output Power (W)	Output Voltage (V)	Output Current (A)	Start Temp. (°F/°C)	Tcase Temp. (°F/°C)	Input Current (A)	Input Power (W)	Inrush Current (A)	THD (%)	Power Factor	Efficiency (%)
Max. 25	10-55	0.35-1.25	Min 32/0	Max. 194/90	0.1@347V	31	Max. 35	Max. 20	Min. 0.9	Typ. 81

## Wire Diagram

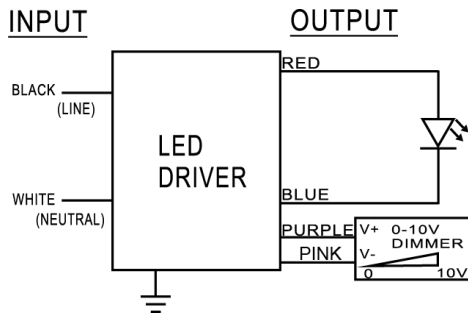

Maximum Wiring Distance (at full load) is 18AWG/18Feet  
LED case should be grounded

Lead Length	Inch	Cm
Black	6	15.2
White	6	15.2
Green	NA	NA
Red	6	15.2
Blue	6	15.2
Purple	7.1	18
Pink	7.1	18

## Enclosure

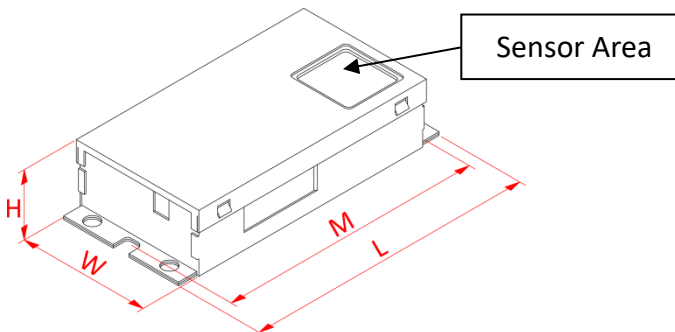

AM111

Enclosure	Inch	Cm
Length(L)	5.23	13.3
Width(W)	2.48	6.3
Height(H)	1.18	3
Mounting(M)	4.84	12.3

# HOW TO USE NFC PROGRAMMING

## 1. Downloading the App

- (1.) Open the **App Store /Google Play** on your smart Phone.
- (2.) Search for **Antron App**.
- (3.) Tap **Download** and wait for the app to install.

## 2. App Setup and Operation

- (1.) **Launch the App**  
Open the app by tapping the Antron LED Driver icon on your home screen.
- (2.) **Ensure NFC is Enabled**  
Verify that the NFC functionality on your device is turned on.
- (3.) **Scan the Driver**  
Place your device's NFC area near the tag's NFC logo to start scanning.
- (4.) **Automatic Detection**  
Once detected, the app will navigate directly to the corresponding operation interface.
- (5.) Before making any setting changes, please ensure that the configured model matches the read driver model. If not, please click "Read" to re-pair the model.



Put your smart phone onto Programmable Driver's NFC area.

## 3. Configuring Driver Settings

- (1.) **Current Settings**  
In the Current field, input the desired current value.  
The maximum and minimum current limits will be displayed below for reference.
- (2.) **Dimming Speed**  
Select either Fast or Slow based on your preference.

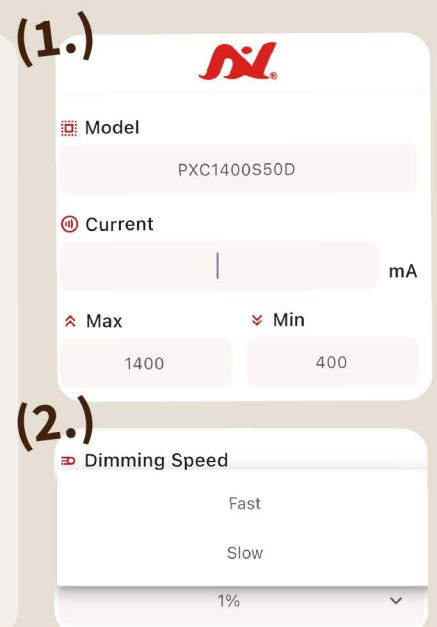

**(3.)**

Dimming Level

1%

OFF

10%

**(4.)**

Dimming Curve

Linear

Log

**(5.)**

Completed



OK

**(3.) Dimming Level**

Adjust the minimum output power via the dimmer to 1%, 10%, or off, according to your requirements.

**(4.) Dimming Curve**

Choose between Linear or Log dimming for your application.

**(5.) Apply Settings**

Once all the desired settings are selected, tap Write and bring your device's NFC area close to the LED Driver's NFC logo to initiate programming. When the screen displays Completed, the scanning and configuration are finished.

## 4. Troubleshooting

**(1.) Unable to Detect the Driver**

Ensure NFC is enabled on your Apple device.

Check that the NFC tag is clean and free of obstructions.

**(2.) Settings Not Applying**

Confirm that the device is properly scanned.

Confirm that the input current value is within the product's maximum and minimum limits.

Retry applying settings and ensure you tap Write.

**(3.) App Crashing or Freezing**

Restart the app or your device.

Ensure you're using the latest app version.

**(4.) Contact Support**

For further assistance, contact our support team:

Email: [info@antron.com.tw](mailto:info@antron.com.tw)



## Programmable Tool

- Put the programmable wand above the NFC mark of the driver to start programming
- Download the software from [www.antron.com.tw](http://www.antron.com.tw)



## I<sub>out</sub> vs V<sub>out</sub> Curve

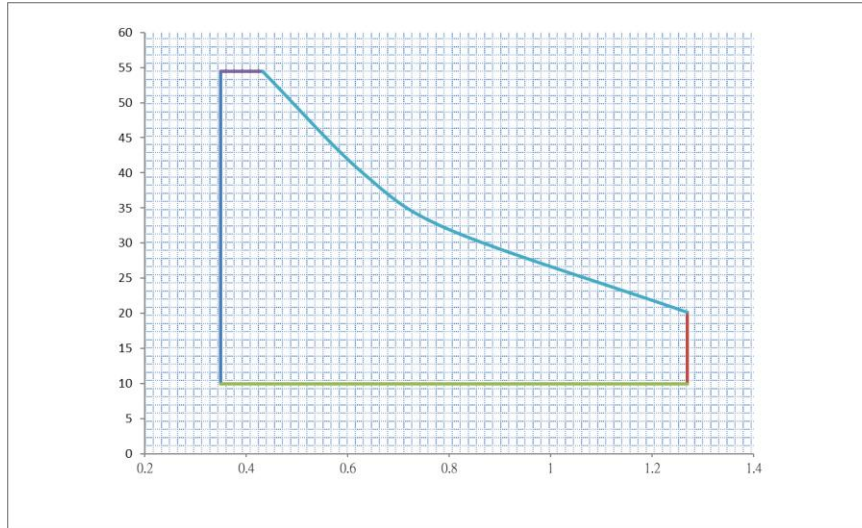

## Output Current Code List

Output Current Code List

Current Value (mA)	Correspond Iout Code				Current Value (mA)	Correspond Iout Code			
	Location					Location			
	0	1	2	3		0	1	2	3
350	01	5E	00	02	850	03	52	00	02
400	01	90	00	02	900	03	84	00	02
450	01	C2	00	02	950	03	B6	00	02
500	01	F4	00	02	1000	03	E8	00	02
550	02	26	00	02	1050	04	1A	00	02
600	02	58	00	02	1100	04	4C	00	02
650	02	8A	00	02	1150	04	7E	00	02
700	02	BC	00	02	1200	04	B0	00	02
750	02	EE	00	02	1250	04	E2	00	02
800	03	20	00	02	1250 OFF	04	E2	01	02

Note: **Factory default current is set to the maximum current unless otherwise specified.** For drivers containing Revision C of their firmware (contact factory for date code of implementation), it is also possible to adjust the minimum dimming level and the dimming speed by programming the location 2.



## Programmable Driver Options (App Note)

All programmable drivers accept a 16-bit hexadecimal code to program the output current (Iout) of the driver. The Iout programming codes are documented in the computer based-programming software (ST-TOOLS.exe) or from the driver's IOUTCODE.pdf file. The Locations below 0, 1, 2, 3 contain the basic code for a specific output current value.

Location | 0 | 1 | 2 | 3 |  
Value | 00 | 00 | 00 | 00 |

For drivers containing Revision C of their firmware (contact factory for date code of implementation), it is also possible to adjust the minimum dimming level and the dimming speed  $\leq 1.0$  sec. This adjustment is made by modifying location 2 of the programming code while keeping the other locations set for the desired output current. Specifically, the location 2 values are defined as:

Linear Dimming	Logarithmic Dimming
<ul style="list-style-type: none"> <li>• 00 =&gt; Dim to 1%</li> <li>• 01 =&gt; Dim-to-OFF</li> <li>• 02 =&gt; Dim to 10%</li> </ul>	<ul style="list-style-type: none"> <li>• 10 =&gt; Dim to 1%</li> <li>• 11 =&gt; Dim-to-OFF</li> <li>• 12 =&gt; Dim to 10%</li> </ul>

## Dimming Curve

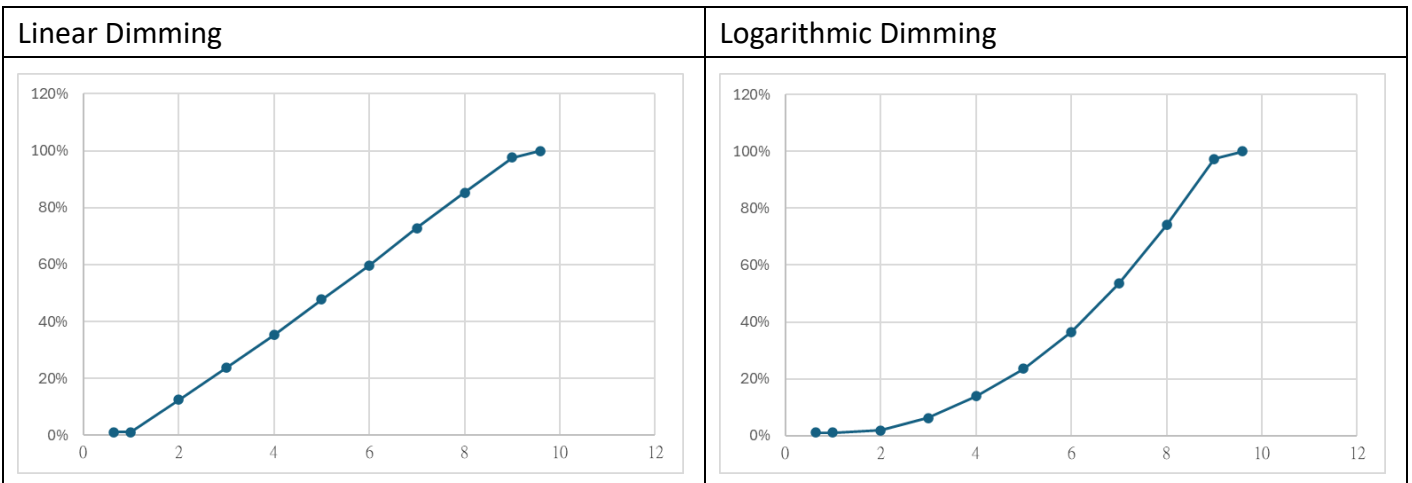

Data is based upon tests performed by Antron Electronics in a controlled environment and representative performance. Actual performance can vary depending on operating conditions. Specifications are subject to change without notice. All specifications are nominal unless otherwise noted.