



<b>Model Name</b>	ESS-386T8HOSX2
<b>Ballast Type</b>	Electronic
<b>Starting Method</b>	Program Start
<b>Lamp connection</b>	Series
<b>Input Voltage</b>	347V
<b>Input Frequency</b>	60Hz
<b>Warranty</b>	5 Years $TC \leq 75^{\circ}C$ 3 Years $75^{\circ}C \leq TC \leq 90^{\circ}C$

## Safety & Performance



- One or Two Lamps
- UL/cUL Listed
- UL Type 1 Outdoor
- FCC part 18 Class A
- Sound Rated Class A
- Class P Thermally Protected
- High Power Factor
- Surge Protected
- Auto Restart
- No PCBs
- Type HL
- NRCAN Energy Verified

## Wire Diagram

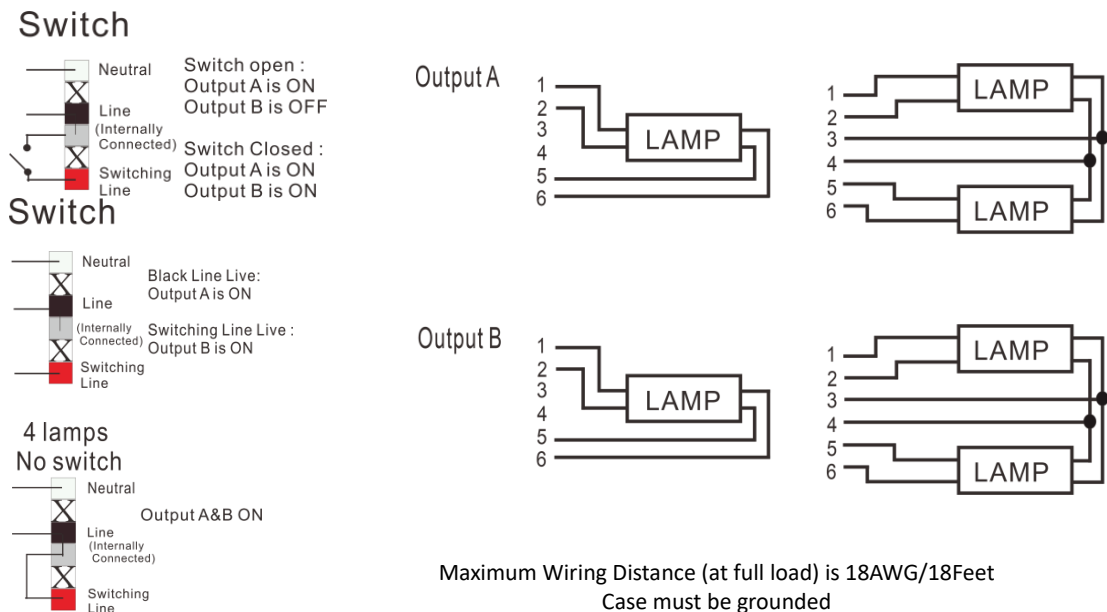

## Enclosure

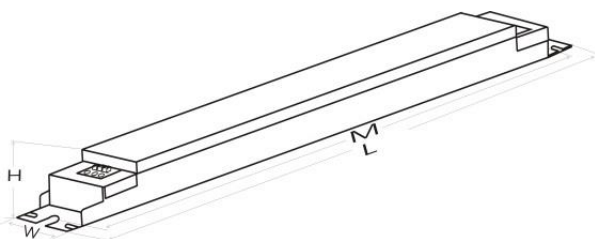

AM94

Enclosure	Inch	Cm
Length(L)	12.8	32.5
Width(W)	2.52	6.4
Height(H)	1.16	2.95
Mounting(M)	12.5	31.7



## Electrical Specification with Different Lamps

Lamp Type	No. of Lamps	Input Voltage (V)	Rated Lamp Watts	Start Temp Min. (F/C)	Input Current (Amps)	Input Power (ANSI Watts)	Ballast Factor	THD Max. (%)	Power Factor	Lamp Current Crest Factor Max.	BEF
F96T8HO	2	347	86	-22/-30	0.531	184	1.03	15	0.99	1.7	0.78
	1				0.27	92	1.00	15	0.98		0.78
F72T8HO	2	347	65	-22/-30	0.40	140	0.94	15	0.99	1.7	0.78
	1				0.23	81	1.00	25	0.98		1.59
F60T8HO	2	347	55	-22/-30	0.34	118	0.92	15	0.99	1.7	0.78
	1				0.20	70	1.00	25	0.97		1.43
F48T8HO	2	347	44	-22/-30	0.28	98	0.95	15	0.98	1.7	0.97
	1				0.17	59	1.02	25	0.96		1.73