



Model Name	EPQ-332T8HO
Ballast Type	Electronic
Starting Method	Instant Start
Lamp connection	Parallel
Input Voltage	347V
Input Frequency	60Hz
Warranty	5 Years $TC \leq 75^{\circ}C$ 3 Years $75^{\circ}C \leq TC \leq 90^{\circ}C$

Safety & Performance



- Three or Four Lamps
- UL/cUL Listed
- UL Type 1 Outdoor
- FCC part 18 Class A
- Sound Rated Class A
- Class P Thermally Protected
- High Power Factor
- Surge Protected
- Auto Restart
- No PCBs
- Open Circuit Voltage 600V
- Type HL

Wire Diagram

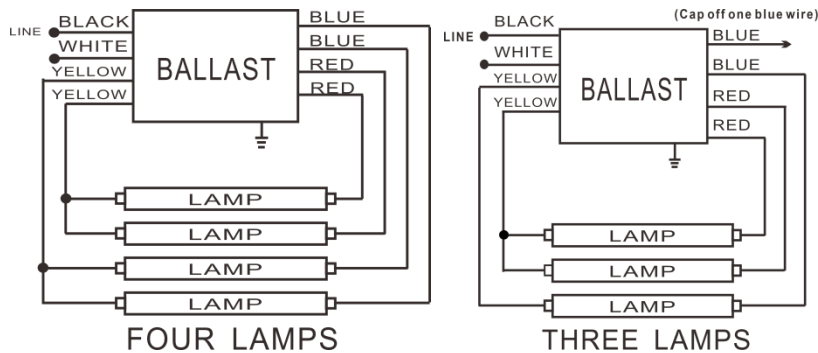

Lead Length	Inch	Cm
Black	18.8	48
White	18.8	48
Blue	30.9	78.5
Red	46.4	118

Maximum Wiring Distance (at full load) is 18AWG/18Feet
Case must be grounded

Enclosure

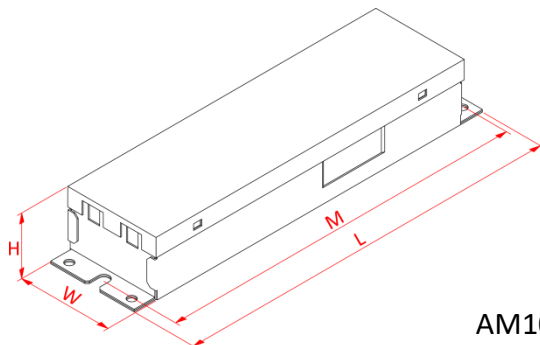

AM105

Enclosure	Inch	Cm
Length(L)	9.5	24.1
Width(W)	2.4	6.1
Height(H)	1.45	3.7
Mounting(M)	8.9	22.6



Electrical Specification with Different Lamps

Lamp Type	No. of Lamps	Input Voltage (V)	Rated Lamp Watts	Start Temp Min. (F/C)	Input Current (Amps)	Input Power (ANSI Watts)	Ballast Factor	THD Max. (%)	Power Factor	Lamp Current Crest Factor Max.	BEF
F32T8	4	347	32	0/-18	0.40	140	1.1	10	0.99	1.7	0.79
	3				0.32	109	1.15	15	0.99		1.06
F25T8	4	347	25	0/-18	0.30	101	1.2	15	0.98	1.7	1.19
	3				0.26	87	1.25	15	0.97		1.44
F17T8	4	347	17	0/-18	0.23	77	1.26	15	0.97	1.7	1.64
	3				0.21	72	1.37	20	0.95		1.90
F40T8	3	347	40	32/0	0.37	127	1.2	10	0.99	1.7	0.94
F32T8/ES (30W)	4	347	30	32/0	0.38	129	1.1	10	0.99	1.7	0.85
	3				0.30	102	1.15	15	0.99		1.13
F32T8/ES (28W)	4	347	28	32/0	0.35	120	1.1	10	0.99	1.7	0.92
	3				0.28	95	1.15	15	0.98		1.21
F32T8/ES (25W)	4	347	25	32/0	0.32	110	1.1	15	0.98	1.7	1.00
	3				0.26	88	1.15	15	0.98		1.31