



Model Name	EPT-A32T8M
Ballast Type	Electronic
Starting Method	Instant Start
Lamp connection	Parallel
Input Voltage	120-277V
Input Frequency	50/60Hz
Warranty	5 Years $TC \leq 75^{\circ}C$ 3 Years $75^{\circ}C \leq TC \leq 90^{\circ}C$

Safety & Performance



- Two or Three Lamps
- UL/cUL Listed
- UL Type 1 Outdoor
- FCC part 18 Class A
- Sound Rated Class A
- Class P Thermally Protected
- High Power Factor
- Surge Protected
- Auto Restart
- No PCBs
- Type HL
- DOE Energy Verified

Wire Diagram

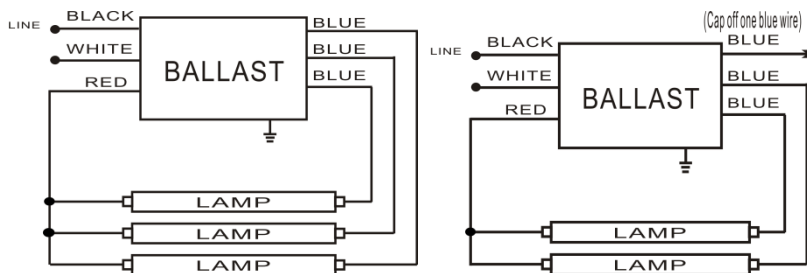

Lead Length	Inch	Cm
Black	18.8	48
White	18.8	48
Blue	30.9	78.5
Red	46.4	118

Maximum Wiring Distance (at full load) is 18AWG/18Feet
Case must be grounded

Enclosure

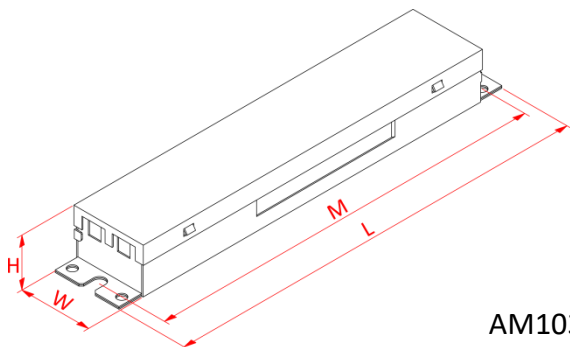

AM103

Enclosure	Inch	Cm
Length(L)	9.5	24.1
Width(W)	1.7	4.3
Height(H)	1.2	3.05
Mounting(M)	8.9	22.6



Electrical Specification with Different Lamps

Lamp Type	No. of Lamps	Input Voltage (V)	Rated Lamp Watts	Start Temp Min. (F/C)	Input Current (Amps)	Input Power (ANSI Watts)	Ballast Factor	THD Max. (%)	Power Factor	Lamp Current Crest Factor Max.	BEF
F32T8	3	120	32	0/-18	0.81	83	0.88	10	0.99	1.7	1.06
		230			0.36			10	0.99		
		277			0.30			10	0.98		
	2	120	32	0/-18	0.56	67	1.00	10	0.99	1.7	1.49
		230			0.29			10	0.98		
		277			0.25			15	0.97		
F25T8	3	120	25	0/-18	0.53	64	0.91	10	0.99	1.7	1.42
		230			0.29			10	0.98		
		277			0.25			15	0.97		
	2	120	25	0/-18	0.42	50	1.03	10	0.99	1.7	2.06
		230			0.23			15	0.98		
		277			0.20			15	0.96		
F17T8	3	120	17	0/-18	0.40	47	0.96	10	0.99	1.7	2.04
		230			0.22			15	0.98		
		277			0.20			15	0.98		
	2	120	17	0/-18	0.30	36	1.05	15	0.98	1.7	2.92
		230			0.17			15	0.98		
		277			0.15			20	0.95		
F40T8	2	120	40	0/-18	0.65	79	0.91	10	0.99	1.7	1.15
		230			0.35			10	0.99		
		277			0.29			10	0.98		



Electrical Specification with Different Lamps

Lamp Type	No. of Lamps	Input Voltage (V)	Rated Lamp Watts	Start Temp Min. (F/C)	Input Current (Amps)	Input Power (ANSI Watts)	Ballast Factor	THD Max. (%)	Power Factor	Lamp Current Crest Factor Max.	BEF
F32T8/ES (30W)	3	120	30	32/0	0.66	79	0.88	10	0.99	1.7	1.11
		230			0.34			10	0.99		
		277			0.29			10	0.98		
	2	120	30	32/0	0.53	64	1.00	10	0.99	1.7	1.56
		230			0.28			15	0.98		
		277			0.23			15	0.97		
F32T8/ES (28W)	3	120	28	32/0	0.62	74	0.88	10	0.99	1.7	1.19
		230			0.32			10	0.99		
		277			0.27			15	0.98		
	2	120	28	32/0	0.47	56	1.00	10	0.99	1.7	1.79
		230			0.24			15	0.98		
		277			0.20			15	0.97		
F32T8/ES (25W)	3	120	25	32/0	0.56	67	0.88	10	0.99	1.7	1.31
		230			0.29			15	0.98		
		277			0.24			15	0.98		
	2	120	25	32/0	0.43	51	1.00	10	0.99	1.7	1.96
		230			0.22			15	0.98		
		277			0.18			15	0.97		