



<b>Model Name</b>	EPT-332T8MLO
<b>Ballast Type</b>	Electronic
<b>Starting Method</b>	Instant Start
<b>Lamp connection</b>	Parallel
<b>Input Voltage</b>	347V
<b>Input Frequency</b>	60Hz
<b>Warranty</b>	5 Years $TC \leq 75^{\circ}C$ 3 Years $75^{\circ}C \leq TC \leq 90^{\circ}C$

## Safety & Performance



- Three or Four Lamps
- UL/cUL Listed
- UL Type 1 Outdoor
- FCC part 18 Class A
- Sound Rated Class A
- Class P Thermally Protected
- High Power Factor
- Surge Protected
- Auto Restart
- No PCBs
- Type HL
- NRCAN Energy Verified

## Wire Diagram

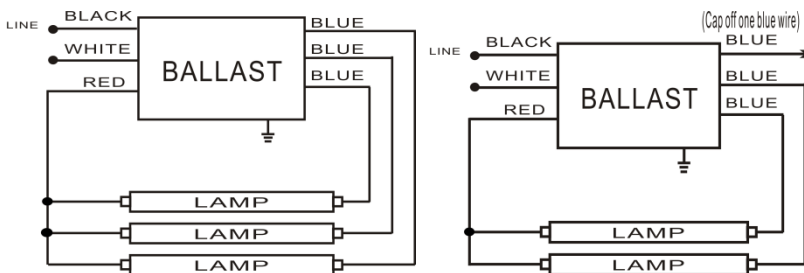

Lead Length	Inch	Cm
Black	18.8	48
White	18.8	48
Blue	30.9	78.5
Red	46.4	118

Maximum Wiring Distance (at full load) is 18AWG/18Feet  
Case must be grounded

## Enclosure

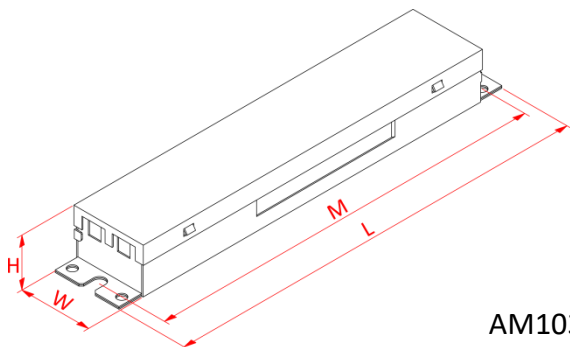

AM103

Enclosure	Inch	Cm
Length(L)	9.5	24.1
Width(W)	1.7	4.3
Height(H)	1.2	3.05
Mounting(M)	8.9	22.6



## Electrical Specification with Different Lamps

Lamp Type	No. of Lamps	Input Voltage (V)	Rated Lamp Watts	Start Temp Min. (F/C)	Input Current (Amps)	Input Power (ANSI Watts)	Ballast Factor	THD Max. (%)	Power Factor	Lamp Current Crest Factor Max.	BEF
F32T8	3	347	32	0/-18	0.21	73	0.79	10	0.98	1.7	1.08
	2				0.16	54	0.86	15	0.98		1.59
F25T8	3	347	25	0/-18	0.17	57	0.79	15	0.98	1.7	1.39
	2				0.13	43	0.88	15	0.97		2.05
F17T8	3	347	17	0/-18	0.12	41	0.82	15	0.97	1.7	2.00
	2				0.09	31	0.90	20	0.96		2.90
F40T8	2	347	40	32/0	0.19	68	0.77	10	0.98	1.7	1.13
F32T8/ES (30W)	3	347	30	32/0	0.20	70	0.79	10	0.98	1.7	1.13
	2				0.15	51	0.86	15	0.97		1.69
F32T8/ES (28W)	3	347	28	32/0	0.19	68	0.79	10	0.98	1.7	1.16
	2				0.14	47	0.86	15	0.97		1.83
F32T8/ES (25W)	3	347	25	32/0	0.17	58	0.79	15	0.99	1.7	1.36
	2				0.13	43	0.86	15	0.97		2.00