



<b>Model Name</b>	EPD-A59T8M
<b>Ballast Type</b>	Electronic
<b>Starting Method</b>	Instant Start
<b>Lamp connection</b>	Parallel
<b>Input Voltage</b>	120-277V
<b>Input Frequency</b>	50/60Hz
<b>Warranty</b>	5 Years $TC \leq 75^{\circ}C$ 3 Years $75^{\circ}C \leq TC \leq 90^{\circ}C$

## Safety & Performance



- One or Two Lamps
- UL/cUL Listed
- UL Type 1 Outdoor
- FCC part 18 Class A
- Sound Rated Class A
- Class P Thermally Protected
- High Power Factor
- Surge Protected
- Auto Restart
- No PCBs
- Type HL
- DOE Energy Verified

## Wire Diagram

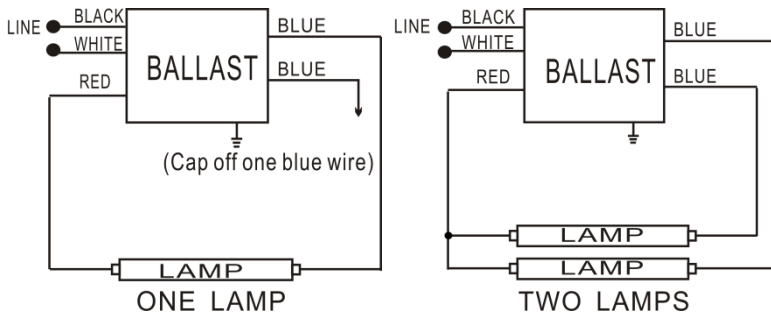

Lead Length	Inch	Cm
Black	18.8	48
White	18.8	48
Blue	30.9	78.5
Red	46.4	118

Maximum Wiring Distance (at full load) is 18AWG/18Feet  
Case must be grounded

## Enclosure

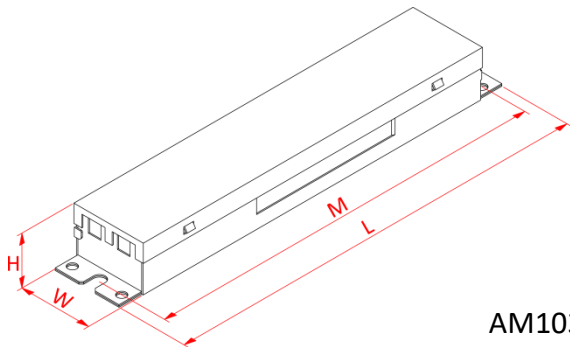

AM103

Enclosure	Inch	Cm
Length(L)	9.5	24.1
Width(W)	1.7	4.3
Height(H)	1.2	3.05
Mounting(M)	8.9	22.6



## Electrical Specification with Different Lamps

Lamp Type	No. of Lamps	Input Voltage (V)	Rated Lamp Watts	Start Temp Min. (F/C)	Input Current (Amps)	Input Power (ANSI Watts)	Ballast Factor	THD Max. (%)	Power Factor	Lamp Current Crest Factor Max.	BEF
F96T8	2	120	59	32/0	0.90	107	0.89	10	0.99	1.7	0.83
		230			0.47			10	0.98		
		277			0.39			10	0.98		
	1	120	59	32/0	0.55	66	1	15	0.98	1.7	1.52
		230			0.29			15	0.98		
		277			0.24			15	0.97		
F96T8/ES	2	120	57	32/0	0.85	102	0.88	10	0.99	1.7	0.86
		230			0.45			10	0.98		
		277			0.37			10	0.99		
	1	120	57	32/0	0.52	62	1	15	0.98	1.7	1.61
		230			0.27			15	0.98		
		277			0.22			15	0.97		