



Model Name	ESD-A54T5LOS
Ballast Type	Electronic
Starting Method	Program Start
Lamp connection	Series
Input Voltage	120-277V
Input Frequency	50/60Hz
Warranty	5 Years $TC \leq 75^{\circ}C$ 3 Years $75^{\circ}C \leq TC \leq 90^{\circ}C$

Safety & Performance



- One or Two lamps
- UL/cUL Listed
- UL Type 1 Outdoor
- FCC part 18 Class A
- Sound Rated Class A
- Class P Thermally Protected
- High Power Factor
- Surge Protected
- Auto Restart
- No PCBs
- Type HL
- DOE Energy Verified

Wire Diagram

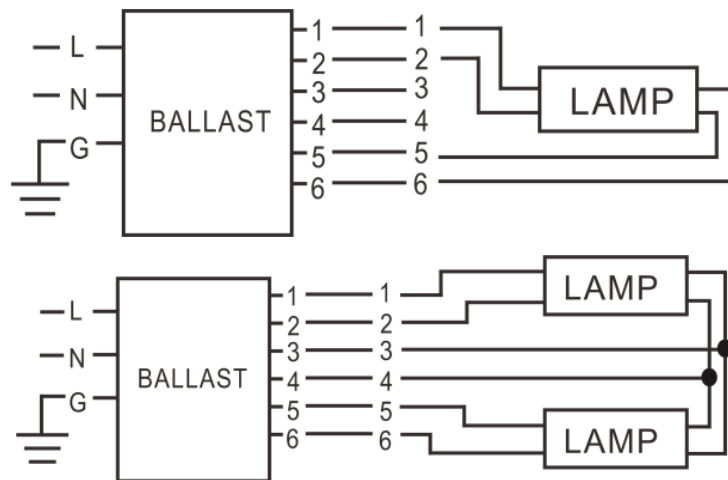

Maximum Wiring Distance (at full load) is 18AWG/18Feet
Case must be grounded

Enclosure

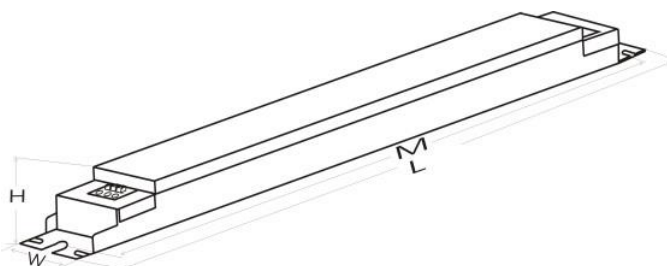

AM24

Enclosure	Inch	Cm
Length(L)	12.8	32.5
Width(W)	1.34	3.4
Height(H)	1.08	2.75
Mounting(M)	12.48	31.7



Electrical Specification with Different Lamps

Lamp Type	No. of Lamps	Input Voltage (V)	Rated Lamp Watts	Start Temp Min. (F/C)	Input Current (Amps)	Input Power (ANSI Watts)	Ballast Factor	THD Max. (%)	Power Factor	Lamp Current Crest Factor Max.	BEF
54W T5HO	2	120	54	-22/-30	0.97	108	0.86	10	0.99	1.7	0.80
		230			0.51			10	0.99		
		277			0.43			15	0.98		
	1	120			0.46	55	0.88	10	0.98		
		230			0.24			15	0.98		
		277			0.20			20	0.97		
54W T5HO/ ES (49W)	2	120	49	-22/-30	0.83	99	0.85	10	0.99	1.7	0.86
		230			0.44			10	0.99		
		277			0.36			15	0.98		
	1	120			0.45	54	0.88	10	0.98		
		230			0.24			15	0.98		
		277			0.20			25	0.97		
54W T5HO/ ES (47W)	2	120	47	-22/-30	0.82	97	0.85	10	0.99	1.7	0.88
		230			0.43			10	0.99		
		277			0.36			15	0.98		
	1	120			0.43	52	0.88	10	0.98		
		230			0.23			15	0.98		
		277			0.20			25	0.97		
55W PLL	2	120	55	-22/-30	0.83	99	0.71	10	0.99	1.7	0.72
		230			0.44			10	0.99		
		277			0.36			15	0.98		
	1	120			0.46	55	0.79	10	0.98		
		230			0.24			15	0.98		
		277			0.20			20	0.97		
39W T5HO	2	120	39	-22/-30	0.64	76	0.85	10	0.99	1.7	1.12
		230			0.34			10	0.99		
		277			0.28			15	0.98		
50W PLL	2	120	50	-22/-30	0.84	100	0.79	10	0.99	1.7	0.79
		230			0.44			10	0.99		
		277			0.37			15	0.98		
	1	120			0.45	53	0.86	10	0.98		
		230			0.24			15	0.98		
		277			0.20			25	0.97		