



Model Name	ESD-335T5SX2
Ballast Type	Electronic
Starting Method	Program Start
Lamp connection	Series
Input Voltage	347V
Input Frequency	60Hz
Warranty	5 Years $TC \leq 75^{\circ}C$ 3 Years $75^{\circ}C \leq TC \leq 90^{\circ}C$

Safety & Performance



- Maximum Four lamps
- Sound Rated Class A
- Auto Restart
- UL/cUL Listed
- Class P Thermally Protected
- No PCBs
- UL Type 1 Outdoor
- High Power Factor
- Type HL
- FCC part 18 Class A
- Surge Protected

Wire Diagram

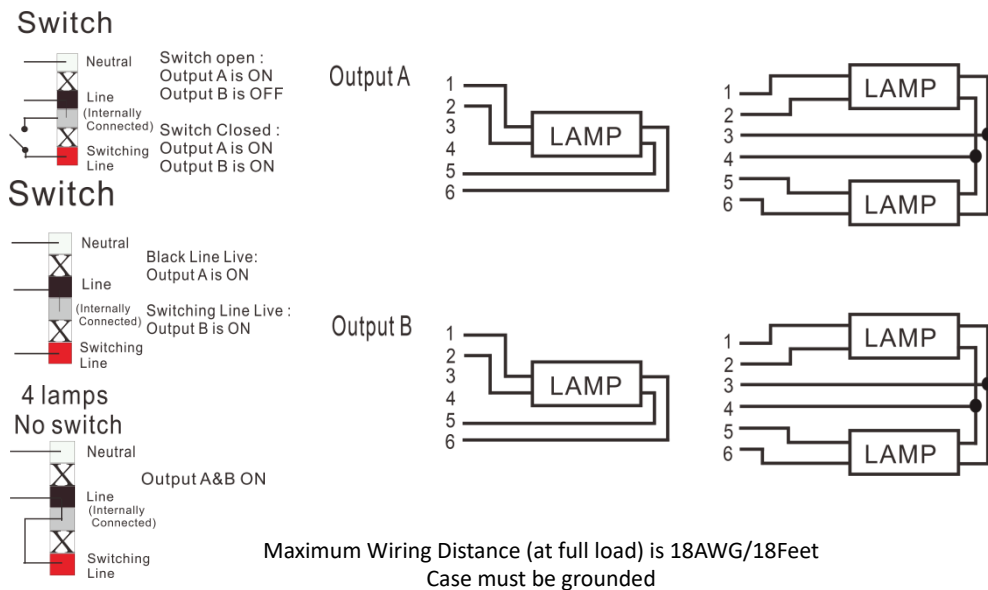

Enclosure

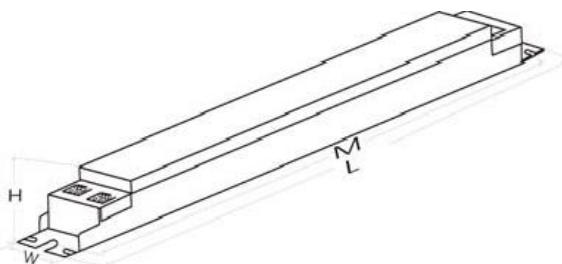

AM94

Enclosure	Inch	Cm
Length(L)	12.8	32.5
Width(W)	2.52	6.4
Height(H)	1.16	2.95
Mounting(M)	12.5	31.7



Electrical Specification with Different Lamps

Lamp Type	No. of Lamps	Input Voltage (V)	Rated Lamp Watts	Start Temp Min. (F/C)	Input Current (Amps)	Input Power (ANSI Watts)	Ballast Factor	THD Max. (%)	Power Factor	Lamp Current Crest Factor Max.	BEF
35W T5	4	347	35	-22/-30	0.45	115	0.9	15	0.98	1.7	1.12
	3				0.33	115	0.93	15	0.98		1.07
	2				0.22	78	0.9	20	0.97		1.12
	1				0.12	40	0.93	25	0.96		2.34
28W T5	4	347	28	-22/-30	0.35	123	0.96	15	0.98	1.7	0.78
	3				0.27	92	0.98	15	0.97		1.07
	2				0.18	62	0.96	15	0.97		1.55
	1				0.09	32	0.98	25	0.96		3.06