



Model Name	ESPQ-335T5S
Ballast Type	Electronic
Starting Method	Program Start
Lamp connection	Series-Parallel
Input Voltage	347V
Input Frequency	60Hz
Warranty	5 Years $TC \leq 75^{\circ}C$ 3 Years $75^{\circ}C \leq TC \leq 90^{\circ}C$

Safety & Performance



- Maximum Four lamps
- UL/cUL Listed
- UL Type 1 Outdoor
- FCC part 18 Class A
- Sound Rated Class A
- Class P Thermally Protected
- High Power Factor
- Surge Protected
- Auto Restart
- No PCBs
- Type HL

Wire Diagram

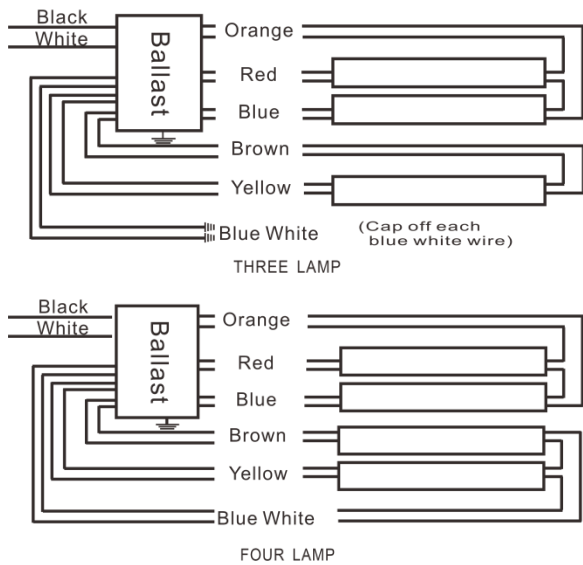

Lead Length	Inch	Cm
Black	18.8	48
White	18.8	48
Blue	30.9	78.5
Red	30.9	78.5
Yellow	46.4	118
Blue/White	46.4	118
Brown	30.9	78.5
Orange	30.9	78.5

Maximum Wiring Distance (at full load) is 18AWG/18Feet
Case must be grounded

Enclosure

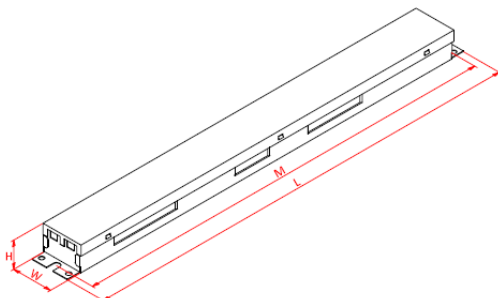

AM104

Enclosure	Inch	Cm
Length(L)	17.7	45
Width(W)	1.7	4.3
Height(H)	1.2	3.0
Mounting(M)	17.2	43.8



Electrical Specification with Different Lamps

Lamp Type	No. of Lamps	Input Voltage (V)	Rated Lamp Watts	Start Temp Min. (F/C)	Input Current (Amps)	Input Power (ANSI Watts)	Ballast Factor	THD Max. (%)	Power Factor	Lamp Current Crest Factor Max.	BEF
35W T5	4	347	35	-22/-30	0.47	166	0.90	15	0.98	1.7	0.54
	3				0.37	127	0.93	15	0.98		0.73
	2				0.24	83	0.90	20	0.98		1.08
	1				0.12	41	1.02	25	0.97		2.49
28W T5	4	347	28	-22/-30	0.40	136	0.93	15	0.98	1.7	0.68
	3				0.30	103	0.96	15	0.98		0.93
	2				0.20	68	0.93	20	0.97		1.37
	1				0.10	35	1.07	25	0.95		3.06