



<b>Model Name</b>	<b>ESD-B21T5S</b>
<b>Ballast Type</b>	Electronic
<b>Starting Method</b>	Program Start
<b>Lamp connection</b>	Series
<b>Input Voltage</b>	347V
<b>Input Frequency</b>	60Hz
<b>Warranty</b>	5 Years $TC \leq 75^{\circ}C$ 3 Years $75^{\circ}C \leq TC \leq 90^{\circ}C$

## Safety & Performance



- One or Two lamps
- UL/cUL Listed
- UL Type 1 Outdoor
- FCC part 18 Class A
- Sound Rated Class A
- Class P Thermally Protected
- High Power Factor
- Surge Protected
- Auto Restart
- No PCBs
- Type HL

## Wire Diagram

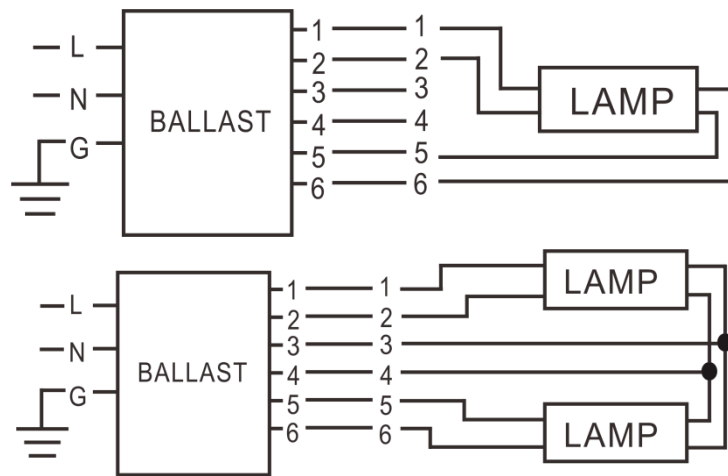

Maximum Wiring Distance (at full load) is 18AWG/18Feet  
Case must be grounded

## Enclosure

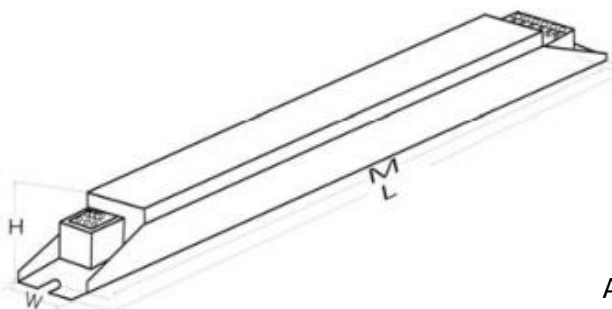

AM34

Enclosure	Inch	Cm
Length(L)	11.5	29.2
Width(W)	1.34	3.4
Height(H)	1.06	2.7
Mounting(M)	11.14	28.3



## Electrical Specification with Different Lamps

Lamp Type	No. of Lamps	Input Voltage (V)	Rated Lamp Watts	Start Temp Min. (F/C)	Input Current (Amps)	Input Power (ANSI Watts)	Ballast Factor	THD Max. (%)	Power Factor	Lamp Current Crest Factor Max.	BEF
21W T5	2	347	21	-22/-30	0.15	49	0.96	15	0.99	1.7	1.96
	1				0.08	26	0.97	20	0.98		3.73
14W PLL	2	347	14	-22/-30	0.1	35	1	15	0.99	1.7	2.86
	1				0.06	19	1	20	0.95		5.26