



<b>Model Name</b>	ESD-354T5S
<b>Ballast Type</b>	Electronic
<b>Starting Method</b>	Program Start
<b>Lamp connection</b>	Series
<b>Input Voltage</b>	347V
<b>Input Frequency</b>	60Hz
<b>Warranty</b>	5 Years $TC \leq 75^{\circ}C$ 3 Years $75^{\circ}C \leq TC \leq 90^{\circ}C$

## Safety & Performance



- One or Two lamps
- UL/cUL Listed
- UL Type 1 Outdoor
- FCC part 18 Class A
- Sound Rated Class A
- Class P Thermally Protected
- High Power Factor
- Surge Protected
- Auto Restart
- No PCBs
- Type HL

## Wire Diagram

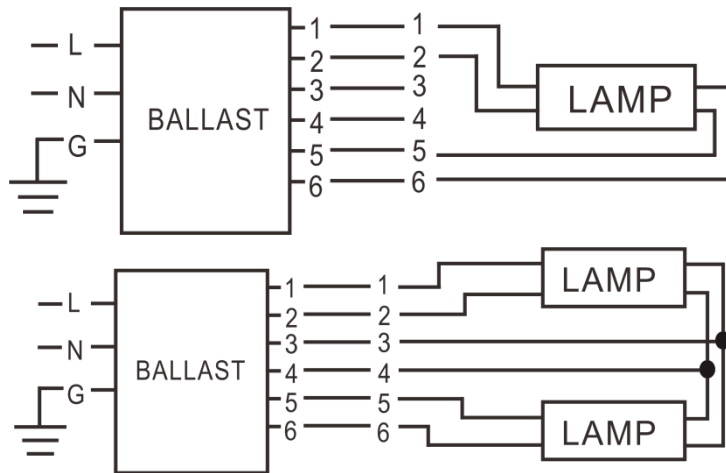

Maximum Wiring Distance (at full load) is 18AWG/18Feet  
Case must be grounded

## Enclosure

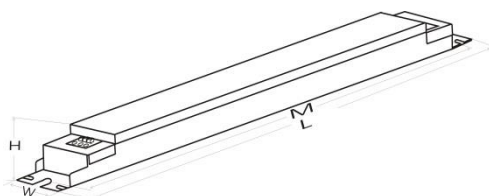

AM34

Enclosure	Inch	Cm
Length(L)	11.5	29.2
Width(W)	1.34	3.4
Height(H)	1.06	2.7
Mounting(M)	11.14	28.3



## Electrical Specification with Different Lamps

Lamp Type	No. of Lamps	Input Voltage (V)	Rated Lamp Watts	Start Temp Min. (F/C)	Input Current (Amps)	Input Power (ANSI Watts)	Ballast Factor	THD Max. (%)	Power Factor	Lamp Current Crest Factor Max.	BEF
54W T5HO	2	347	54	-22/-30	0.34	119	0.93	10	0.99	1.7	0.78
	1				0.18	61	0.97	15	0.99		1.59
54W T5HO/ES (49W)	2	347	49	-22/-30	0.32	109	0.93	15	0.98	1.7	0.85
	1				0.17	59	0.97	20	0.97		1.64
54W T5HO/ES (47W)	2	347	47	-22/-30	0.30	107	0.93	15	0.98	1.7	0.72
	1				0.16	57	0.97	20	0.97		1.70
55W PLL	2	347	55	-22/-30	0.32	109	0.78	10	0.99	1.7	0.72
	1				0.18	60	0.87	15	0.98		1.45
39W T5HO	2	347	39	-22/-30	0.25	84	0.93	15	0.99	1.7	1.11
50W PLL	2	347	50	-22/-30	0.32	110	0.87	10	0.99	1.7	0.79
	1				0.17	58	0.95	15	0.98		1.64