



<b>Model Name</b>	FSD-A18PS
<b>Ballast Type</b>	Electronic
<b>Starting Method</b>	Program Start
<b>Lamp connection</b>	Series
<b>Input Voltage</b>	120-277V
<b>Input Frequency</b>	50/60Hz
<b>Warranty</b>	5 Years $TC \leq 75^{\circ}C$ 3 Years $75^{\circ}C \leq TC \leq 90^{\circ}C$

## Safety & Performance



- One or Two lamps
- UL/cUL Listed
- UL Type 1 Outdoor
- FCC part 18 Class A
- Sound Rated Class A
- Class P Thermally Protected
- High Power Factor
- Surge Protected
- Auto Restart
- No PCBs
- Type HL

## Wire Diagram

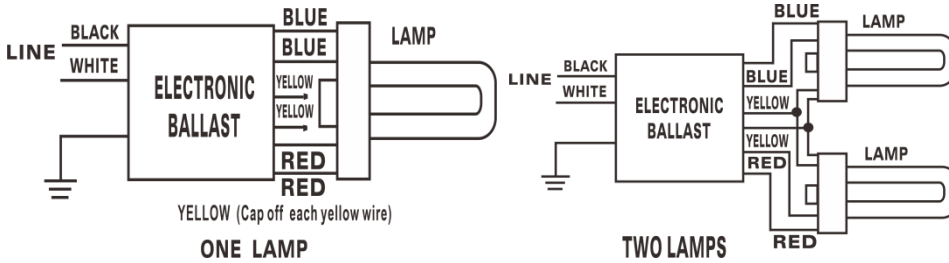

Lead Length	Inch	Cm
Black	18.8	48
White	18.8	48
Blue	18.8	48
Red	18.8	48
Yellow	24	61

Maximum Wiring Distance (at full load) is 18AWG/18Feet  
Case must be grounded

## Enclosure

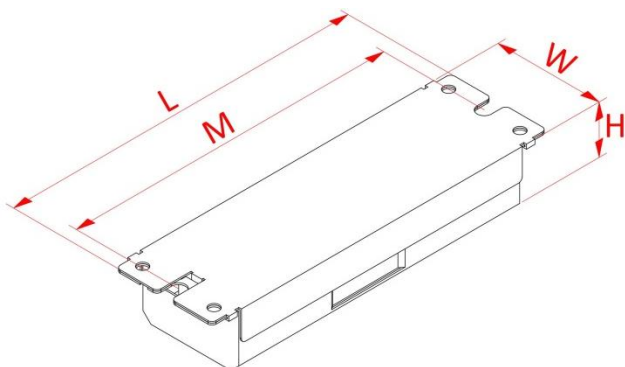

AM26

Enclosure	Inch	Cm
Length(L)	6.5	16.4
Width(W)	1.93	4.9
Height(H)	1.18	3.0
Mounting(M)	5.9	15



## Electrical Specification with Different Lamps

Lamp Type	No. of Lamps	Input Voltage (V)	Rated Lamp Watts	Start Temp Min. (F/C)	Input Current (Amps)	Input Power (ANSI Watts)	Ballast Factor	THD Max. (%)	Power Factor	Lamp Current Crest Factor Max.	BEF	
PLT-18W	2	120	18	-22/-30	0.33	39	0.86	10	0.99	1.7	2.21	
		230			0.17			10	0.99			
		277			0.14			15	0.98			
	1	120			0.17	20		0.92	10			0.99
		230			0.09				15			0.98
		277			0.08				15			0.97
PLT-13W	2	120	13	-22/-30	0.27	33	0.98	10	0.99	1.7	2.97	
		230			0.15			10	0.99			
		277			0.12			10	0.98			
	1	120			0.14	17		0.94	10			0.99
		230			0.08				15			0.98
		277			0.07				20			0.95
F17T8	2	120	17	-22/-30	0.28	34	0.91	10	0.99	1.7	2.68	
		230			0.15			10	0.99			
		277			0.13			10	0.98			
2D 16W	2	120	16	-22/-30	0.28	34	0.7	10	0.99	1.7	2.06	
		230			0.16			10	0.99			
		277			0.13			10	0.98			
	1	120			0.15	18		0.74	10			0.99
		230			0.08				15			0.98
		277			0.07				15			0.96
2D 38W	1	120	38	-22/-30	0.21	25	0.42	10	0.99	1.7	1.68	
		230			0.11			10	0.99			
		277			0.1			10	0.98			
2D 28W	1	120	28	-22/-30	0.21	25	0.57	10	0.99	1.7	2.28	
		230			0.11			10	0.99			
		277			0.1			15	0.97			
2D 21W	1	120	21	-22/-30	0.17	20	0.6	10	0.99	1.7	3.00	
		230			0.09			15	0.98			
		277			0.08			15	0.96			
F25T8	1	120	25	-22/-30	0.15	17	0.46	10	0.99	1.7	2.71	
		230			0.08			15	0.98			
		277			0.07			20	0.95			
28WT5	1	120	28	-22/-30	0.29	36	1.05	10	0.99	1.7	2.92	
		230			0.16			10	0.99			
		277			0.14			10	0.98			
21WT5	1	120	21	-22/-30	0.22	27	0.93	10	0.99	1.7	3.44	
		230			0.12			10	0.99			
		277			0.1			10	0.98			
14WT5	1	120	14	-22/-30	0.14	19	1.03	10	0.99	1.7	5.42	
		230			0.09			15	0.98			
		277			0.08			15	0.96			



## Electrical Specification with Different Lamps

Lamp Type	No. of Lamps	Input Voltage (V)	Rated Lamp Watts	Start Temp Min. (F/C)	Input Current (Amps)	Input Power (ANSI Watts)	Ballast Factor	THD Max. (%)	Power Factor	Lamp Current Crest Factor Max.	BEF
9WT5	1	120	9	-22/-30	0.12	14	0.98	10	0.99	1.7	7.00
		230			0.06			15	0.98		
		277			0.06			20	0.95		
PLT-26W	1	120	26	-22/-30	0.19	23	0.74	10	0.99	1.7	3.22
		230			0.1			10	0.98		
		277			0.09			15	0.97		